

## SS8050

SS8050

### 2W Output Amplifier of Portable Radios in Class B Push-pull Operation.

- Complimentary to SS8550
- Collector Current:  $I_C=1.5A$
- Collector Power Dissipation:  $P_C=2W$  ( $T_C=25^\circ C$ )

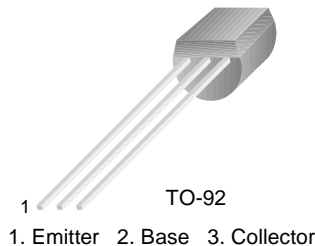

### NPN Epitaxial Silicon Transistor

#### Absolute Maximum Ratings $T_a=25^\circ C$ unless otherwise noted

Symbol	Parameter	Ratings	Units
$V_{CBO}$	Collector-Base Voltage	40	V
$V_{CEO}$	Collector-Emitter Voltage	25	V
$V_{EBO}$	Emitter-Base Voltage	6	V
$I_C$	Collector Current	1.5	A
$P_C$	Collector Power Dissipation	1	W
$T_J$	Junction Temperature	150	$^\circ C$
$T_{STG}$	Storage Temperature	-65 ~ 150	$^\circ C$

#### Electrical Characteristics $T_a=25^\circ C$ unless otherwise noted

Symbol	Parameter	Test Condition	Min.	Typ.	Max.	Units
$BV_{CBO}$	Collector-Base Breakdown Voltage	$I_C=100\mu A, I_E=0$	40			V
$BV_{CEO}$	Collector-Emitter Breakdown Voltage	$I_C=2mA, I_B=0$	25			V
$BV_{EBO}$	Emitter-Base Breakdown Voltage	$I_E=100\mu A, I_C=0$	6			V
$I_{CBO}$	Collector Cut-off Current	$V_{CB}=35V, I_E=0$			100	nA
$I_{EBO}$	Emitter Cut-off Current	$V_{EB}=6V, I_C=0$			100	nA
$h_{FE1}$	DC Current Gain	$V_{CE}=1V, I_C=5mA$	45	135		
$h_{FE2}$		$V_{CE}=1V, I_C=100mA$	85	160	300	
$h_{FE3}$		$V_{CE}=1V, I_C=800mA$	40	110		
$V_{CE(sat)}$	Collector-Emitter Saturation Voltage	$I_C=800mA, I_B=80mA$		0.28	0.5	V
$V_{BE(sat)}$	Base-Emitter Saturation Voltage	$I_C=800mA, I_B=80mA$		0.98	1.2	V
$V_{BE(on)}$	Base-Emitter On Voltage	$V_{CE}=1V, I_C=10mA$		0.66	1	V
$C_{ob}$	Output Capacitance	$V_{CB}=10V, I_E=0$ $f=1MHz$		9.0		pF
$f_T$	Current Gain Bandwidth Product	$V_{CE}=10V, I_C=50mA$	100	190		MHz

#### $h_{FE}$ Classification

Classification	B	C	D
$h_{FE2}$	85 ~ 160	120 ~ 200	160 ~ 300

# Typical Characteristics

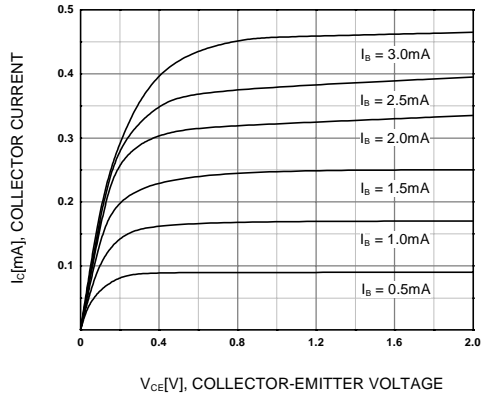

Figure 1. Static Characteristic

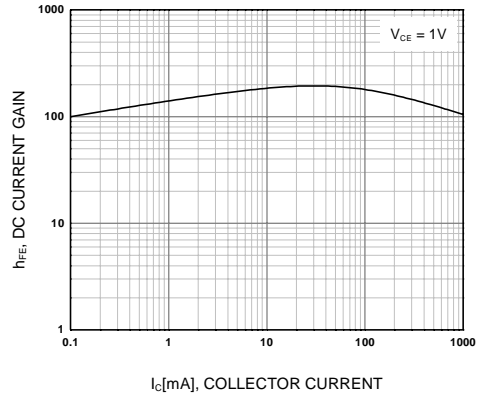

Figure 2. DC current Gain

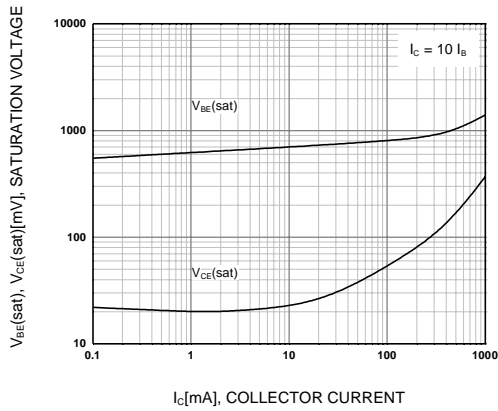

Figure 3. Base-Emitter Saturation Voltage  
Collector-Emitter Saturation Voltage

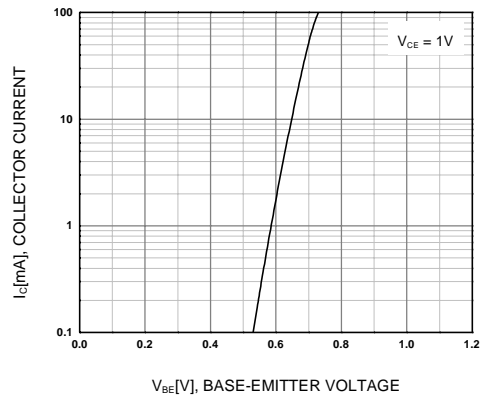

Figure 4. Base-Emitter On Voltage

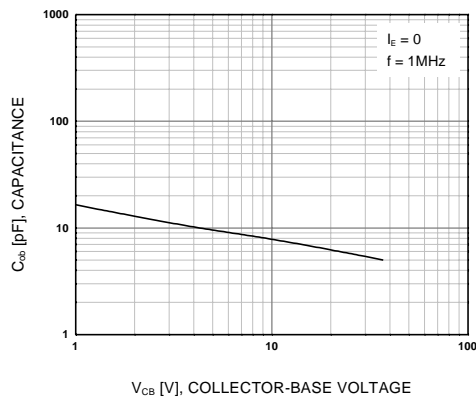

Figure 5. Collector Output Capacitance

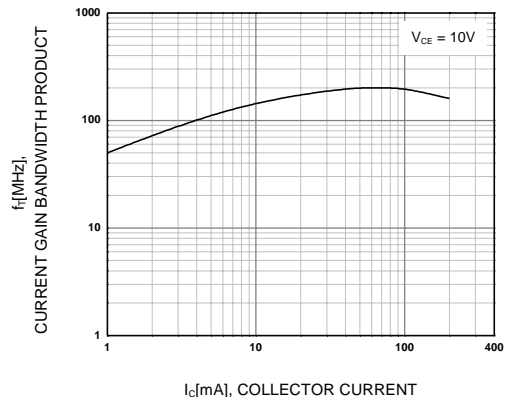
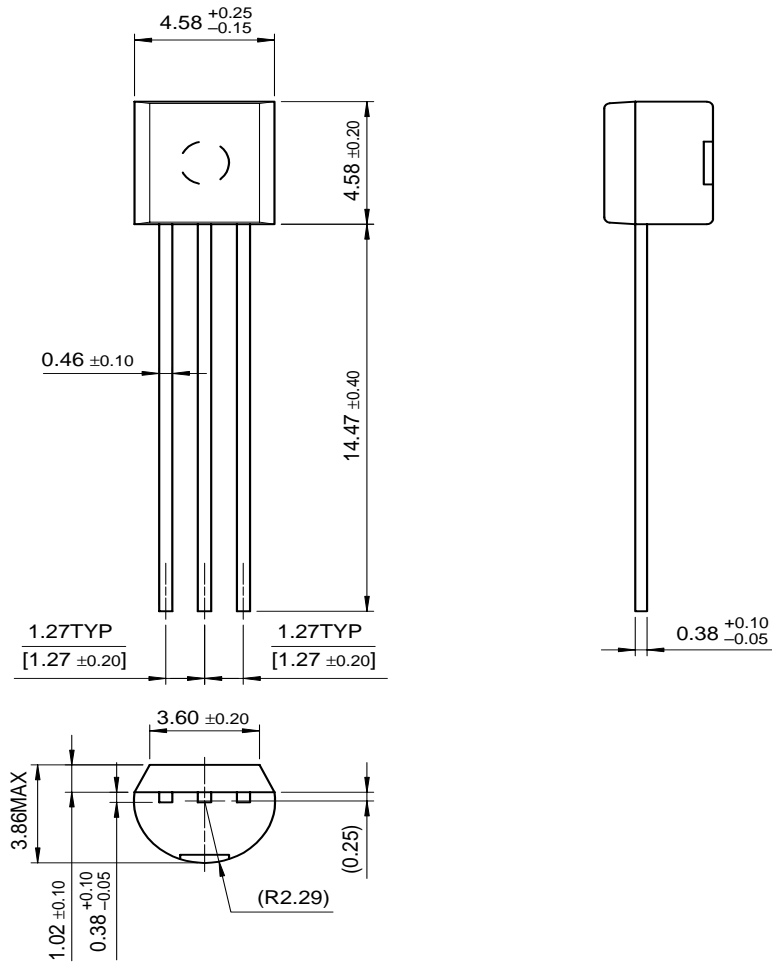

Figure 6. Current Gain Bandwidth Product

# Package Dimensions

SS8050

## TO-92



Dimensions in Millimeters